

**GATE 2022 General Aptitude (GA)****Q.1 – Q.5 Carry ONE mark each.**

Q.1	Mr. X speaks _____ Japanese _____ Chinese.
(A)	neither / or
(B)	either / nor
(C)	neither / nor
(D)	also / but

Q.2	A sum of money is to be distributed among P, Q, R, and S in the proportion 5 : 2 : 4 : 3, respectively. If R gets ₹ 1000 more than S, what is the share of Q (in ₹)?
(A)	500
(B)	1000
(C)	1500
(D)	2000

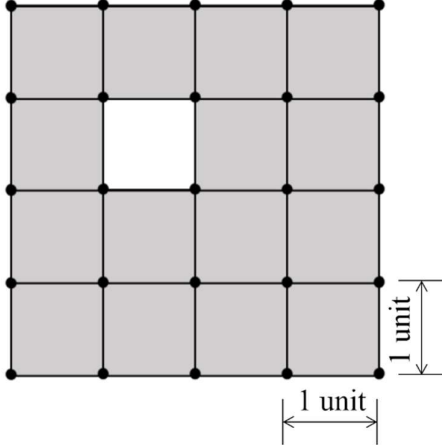

Q.3	<p>A trapezium has vertices marked as P, Q, R and S (in that order anticlockwise). The side PQ is parallel to side SR.</p> <p>Further, it is given that, $PQ = 11$ cm, $QR = 4$ cm, $RS = 6$ cm and $SP = 3$ cm.</p> <p>What is the shortest distance between PQ and SR (in cm)?</p>
(A)	1.80
(B)	2.40
(C)	4.20
(D)	5.76

<p>Q.4</p>	<p>The figure shows a grid formed by a collection of unit squares. The unshaded unit square in the grid represents a hole.</p>  <p>What is the maximum number of squares without a “hole in the interior” that can be formed within the 4×4 grid using the unit squares as building blocks?</p>
<p>(A) 15</p>	
<p>(B) 20</p>	
<p>(C) 21</p>	
<p>(D) 26</p>	

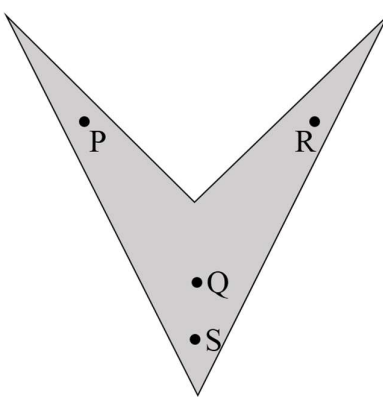
<p>Q.5</p>	<p>An art gallery engages a security guard to ensure that the items displayed are protected. The diagram below represents the plan of the gallery where the boundary walls are opaque. The location the security guard posted is identified such that all the inner space (shaded region in the plan) of the gallery is within the line of sight of the security guard.</p> <p>If the security guard does not move around the posted location and has a 360° view, which one of the following correctly represents the set of ALL possible locations among the locations P, Q, R and S, where the security guard can be posted to watch over the entire inner space of the gallery.</p> <div style="text-align: center;">  </div>
<p>(A) P and Q</p>	
<p>(B) Q</p>	
<p>(C) Q and S</p>	
<p>(D) R and S</p>	



Q. 6 – Q. 10 Carry TWO marks each.

<p>Q.6</p>	<p>Mosquitoes pose a threat to human health. Controlling mosquitoes using chemicals may have undesired consequences. In Florida, authorities have used genetically modified mosquitoes to control the overall mosquito population. It remains to be seen if this novel approach has unforeseen consequences.</p> <p>Which one of the following is the correct logical inference based on the information in the above passage?</p>
<p>(A)</p>	<p>Using chemicals to kill mosquitoes is better than using genetically modified mosquitoes because genetic engineering is dangerous</p>
<p>(B)</p>	<p>Using genetically modified mosquitoes is better than using chemicals to kill mosquitoes because they do not have any side effects</p>
<p>(C)</p>	<p>Both using genetically modified mosquitoes and chemicals have undesired consequences and can be dangerous</p>
<p>(D)</p>	<p>Using chemicals to kill mosquitoes may have undesired consequences but it is not clear if using genetically modified mosquitoes has any negative consequence</p>



Q.7	<p>Consider the following inequalities.</p> <p>(i) $2x - 1 > 7$</p> <p>(ii) $2x - 9 < 1$</p> <p>Which one of the following expressions below satisfies the above two inequalities?</p>
(A)	$x \leq -4$
(B)	$-4 < x \leq 4$
(C)	$4 < x < 5$
(D)	$x \geq 5$

Q.8	<p>Four points P(0, 1), Q(0, -3), R(-2, -1), and S(2, -1) represent the vertices of a quadrilateral.</p> <p>What is the area enclosed by the quadrilateral?</p>
(A)	4
(B)	$4\sqrt{2}$
(C)	8
(D)	$8\sqrt{2}$



<p>Q.9</p>	<p>In a class of five students P, Q, R, S and T, only one student is known to have copied in the exam. The disciplinary committee has investigated the situation and recorded the statements from the students as given below.</p> <p>Statement of P: R has copied in the exam.</p> <p>Statement of Q: S has copied in the exam.</p> <p>Statement of R: P did not copy in the exam.</p> <p>Statement of S: Only one of us is telling the truth.</p> <p>Statement of T: R is telling the truth.</p> <p>The investigating team had authentic information that S never lies.</p> <p>Based on the information given above, the person who has copied in the exam is</p>
<p>(A) R</p>	
<p>(B) P</p>	
<p>(C) Q</p>	
<p>(D) T</p>	

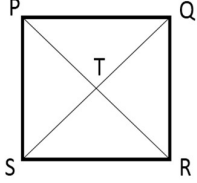

<p>Q.10</p>	<p>Consider the following square with the four corners and the center marked as P, Q, R, S and T respectively.</p> <p>Let X, Y and Z represent the following operations:</p> <p>X: rotation of the square by 180 degree with respect to the S-Q axis.</p> <p>Y: rotation of the square by 180 degree with respect to the P-R axis.</p> <p>Z: rotation of the square by 90 degree clockwise with respect to the axis perpendicular, going into the screen and passing through the point T.</p> <p>Consider the following three distinct sequences of operation (which are applied in the left to right order).</p> <p>(1) XYZZ (2) XY (3) ZZZZ</p> <p>Which one of the following statements is correct as per the information provided above?</p>	
<p>(A)</p>	<p>The sequence of operations (1) and (2) are equivalent</p>	
<p>(B)</p>	<p>The sequence of operations (1) and (3) are equivalent</p>	
<p>(C)</p>	<p>The sequence of operations (2) and (3) are equivalent</p>	
<p>(D)</p>	<p>The sequence of operations (1), (2) and (3) are equivalent</p>	



GATE 2022 Metallurgical Engineering (MT)

Q.11 – Q.29 Multiple Choice Question (MCQ), carry ONE mark each

Q.11	The Taylor series expansion around $x = 0$ of the function $f(x) = \frac{x+1}{e^x + 1}$ truncated to first two terms is _____
(A)	$\frac{1}{2} + \frac{1}{4}x$
(B)	$\frac{1}{2} + \frac{1}{2}x$
(C)	$\frac{1}{2} + x$
(D)	$\frac{1}{2} + 2x$

Q.12	According to Sieverts' law, the equilibrium solubility of N_2 (gas) in molten steel is proportional to _____ Given: Equilibrium partial pressure of N_2 (gas) is p_{N_2}
(A)	p_{N_2}
(B)	$\sqrt{p_{N_2}}$
(C)	$\frac{1}{p_{N_2}}$
(D)	$p_{N_2}^2$



GATE 2022 Metallurgical Engineering (MT)

Q.13	Titanium is produced commercially by _____
(A)	smelting reduction of TiO_2
(B)	thermal dissociation of TiH_2
(C)	reduction of TiCl_4 by Mg
(D)	reduction of TiO_2 by H_2

Q.14	Magnesium treatment is carried out to produce _____ cast iron.
(A)	white
(B)	gray
(C)	spheroidal graphite
(D)	malleable



GATE 2022 Metallurgical Engineering (MT)

Q.15	The sequence of peaks corresponding to the planes (in the order of increasing 2θ) observed in the X-ray diffractogram of a pure copper powder sample is _____
(A)	111, 200, 220, 311
(B)	110, 200, 211, 220
(C)	110, 200, 211, 311
(D)	111, 200, 311, 220

Q.16	Which one of the following Non Destructive Testing (NDT) techniques CANNOT be used to identify volume defects in the interior of a casting?
(A)	Ultrasonic testing
(B)	X-ray computed tomography
(C)	Dye-penetrant testing
(D)	Gamma ray radiography



GATE 2022 Metallurgical Engineering (MT)

Q.17	Neutral point in rolling is defined as the point along the surface of contact between the roll and the sheet, where the surface velocity of the roll is _____
(A)	zero
(B)	half the velocity of the sheet
(C)	twice the velocity of the sheet
(D)	equal to the velocity of the sheet

Q.18	In fluid flow, the dimensionless number that describes the transition from laminar to turbulent flow is _____
(A)	Reynolds number
(B)	Schmidt number
(C)	Biot number
(D)	Prandtl number



GATE 2022 Metallurgical Engineering (MT)

Q.19	Which one of the following elements has the slowest removal rate from hot metal in basic oxygen furnace (BOF) steelmaking?
(A)	Carbon
(B)	Sulfur
(C)	Silicon
(D)	Phosphorus

Q.20	Match the nature of bonding (Column I) with material (Column II)	
	Column I	Column II
	(P) Ionic	(1) Diamond
	(Q) Covalent	(2) Silver
	(R) Metallic	(3) NaCl
	(S) Secondary	(4) Solid argon
(A)	P – 4, Q – 3, R – 2, S – 1	
(B)	P – 2, Q – 1, R – 3, S – 4	
(C)	P – 3, Q – 1, R – 4, S – 2	
(D)	P – 3, Q – 1, R – 2, S – 4	

GATE 2022 Metallurgical Engineering (MT)

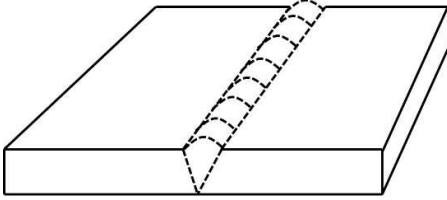
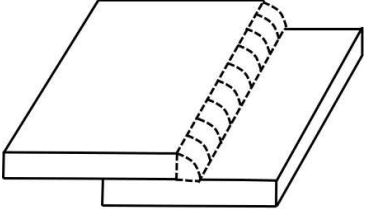
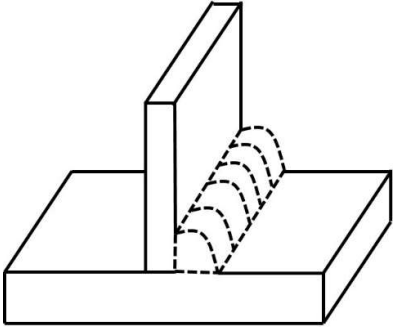
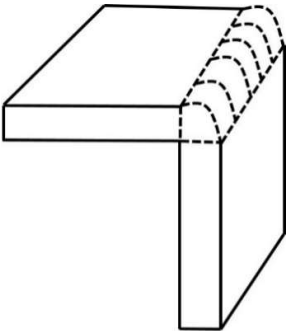
Q.21	Which one of the following figures illustrates a lap joint with fillet weld?
	<div style="display: flex; justify-content: space-around; align-items: center;"> <div style="text-align: center;">  <p>(I)</p> </div> <div style="text-align: center;">  <p>(II)</p> </div> </div> <div style="display: flex; justify-content: space-around; align-items: center; margin-top: 20px;"> <div style="text-align: center;">  <p>(III)</p> </div> <div style="text-align: center;">  <p>(IV)</p> </div> </div>
(A)	I
(B)	II
(C)	III
(D)	IV

GATE 2022 Metallurgical Engineering (MT)

<p>Q.22</p>	<p>The CCT diagram of a eutectoid steel with a superimposed cooling curve is shown in the figure. The microstructure at room temperature (RT) after this heat treatment is _____</p>
<p>(A)</p>	<p>pearlite only</p>
<p>(B)</p>	<p>pearlite + retained austenite</p>
<p>(C)</p>	<p>martensite only</p>
<p>(D)</p>	<p>pearlite + martensite</p>



GATE 2022 Metallurgical Engineering (MT)

Q.23	Given that V is a closed volume in space bounded by the surface S with unit normal \vec{n} . If \vec{f} is any non-zero vector and $\vec{\nabla}$ is the gradient operator, then the volume integral $\int_V (\vec{\nabla} \cdot \vec{f}) dV$ is equal to the surface integral $\int_S (\vec{n} \cdot \vec{f}) dS$ by virtue of _____
(A)	Stokes Curl theorem
(B)	Reynolds transport theorem
(C)	Buckingham Pi theorem
(D)	Gauss divergence theorem

Q.24	In green sand moulding, the casting defect resulting from the displacement of mould cavity by an oversized core is known as _____
(A)	crush
(B)	hot tear
(C)	blow
(D)	fin

**GATE 2022 Metallurgical Engineering (MT)**

Q.25	Which one of the following modern practices is used for retarding the solution loss reaction in blast furnace ironmaking?
(A)	High top pressure
(B)	Bell-less top
(C)	Pulverized coal injection
(D)	Rotating chute for burden distribution

Q.26	For a material that undergoes strain hardening, necking instability occurs during tensile testing when _____ Given: σ = true stress and ϵ = true strain.
(A)	$\frac{d\sigma}{d\epsilon} = 0$
(B)	$\frac{d\sigma}{d\epsilon} = \epsilon$
(C)	$\frac{d\sigma}{d\epsilon} = \sigma$
(D)	$\frac{d\sigma}{d\epsilon} = \infty$



GATE 2022 Metallurgical Engineering (MT)

Q.27	Match the processes (Column I) with the corresponding defects (Column II).	
	Column I	Column II
	(P) Extrusion	(1) Earing
	(Q) Deep drawing	(2) Cold shut
	(R) Forging	(3) Edge cracking
	(S) Rolling	(4) Fir-tree cracking
(A)	P – 1, Q – 4, R – 2, S – 3	
(B)	P – 2, Q – 1, R – 4, S – 3	
(C)	P – 4, Q – 1, R – 3, S – 2	
(D)	P – 4, Q – 1, R – 2, S – 3	

Q.28	With increase in carbon content (up to 2 mass%) in Fe-C alloy, which one of the following statements is correct with respect to the lattice parameters (c and a) of BCT martensite?
(A)	Both c and a increase
(B)	c increases but a decreases
(C)	c decreases but a increases
(D)	Both c and a decrease



GATE 2022 Metallurgical Engineering (MT)

Q.29	With reference to the stress intensity factor, find the correct match of nomenclature (Column A) with the mode of deformation applied to the crack (Column B).	
	<p>Column A</p> <p>(P) Mode I</p> <p>(Q) Mode II</p> <p>(R) Mode III</p>	<p>Column B</p> <p>(X) Forward shear mode</p> <p>(Y) Parallel shear mode</p> <p>(Z) Crack opening mode</p>
(A)	P – Z, Q – Y, R – X	
(B)	P – Z, Q – X, R – Y	
(C)	P – Y, Q – X, R – Z	
(D)	P – Y, Q – Z, R – X	



GATE 2022 Metallurgical Engineering (MT)

Q.30 – Q.33 Multiple Selection Question (MSQ), carry ONE mark each

Q.30	In continuous casting of steel, mould flux is used for _____
(A)	lubrication
(B)	reducing heat loss
(C)	inclusion control
(D)	reducing solidification shrinkage

Q.31	Identify the correct statement(s) with respect to the role of nickel as an alloying element in steels.
(A)	It increases the M_s temperature
(B)	It is an austenite stabiliser
(C)	It decreases the M_s temperature
(D)	It is a carbide former



GATE 2022 Metallurgical Engineering (MT)

Q.32	While designing a material for high temperature application, which of the following characteristic(s)/attribute(s) is(are) desirable for achieving better creep resistance?
(A)	Fine grain size
(B)	FCC crystal structure
(C)	High melting point
(D)	Cold worked microstructure

Q.33	Given the strain rate ($\dot{\epsilon}$), dislocation density (ρ), dislocation velocity (v), which of the following relationship(s) is(are) correct? Assume that Orowan equation for plastic flow due to the dislocation movement is obeyed.
(A)	$\dot{\epsilon} \propto v^2$
(B)	$\dot{\epsilon} \propto v$
(C)	$\dot{\epsilon} \propto \rho^2$
(D)	$\dot{\epsilon} \propto \rho$



GATE 2022 Metallurgical Engineering (MT)

Q.34 – Q.35 Numerical Answer Type (NAT), carry ONE mark each

Q.34	A set of observations with normal distribution of error as $\pm 1.96\sigma$ (where σ is standard deviation) is equivalent to the confidence interval of _____% (round off to the nearest integer).
------	---

Q.35	<p>A Newtonian incompressible liquid is contained between two parallel metal plates separated by 10^{-3} m (see figure). A stress of 5 Pa is required to maintain the upper plate in motion with a constant speed of $2 \text{ m}\cdot\text{s}^{-1}$ in the horizontal direction relative to the bottom plate.</p> <p>The viscosity of liquid contained between the plates is _____ $\times 10^{-3} \text{ Pa}\cdot\text{s}$ (answer rounded off to 1 decimal place).</p>
	<p>The diagram shows two horizontal grey rectangular plates, one above the other, both labeled 'Plate'. Between them is a liquid layer labeled 'Liquid', represented by several horizontal dashed lines. To the right of the liquid layer, a vertical double-headed arrow indicates the distance between the plates, labeled as 10^{-3} m.</p>



GATE 2022 Metallurgical Engineering (MT)

Q.36 – Q.42 Multiple Choice Question (MCQ), carry TWO marks each

Q.36	The general solution to the following differential equation is _____, where A and B are constants
	$\frac{d^2y}{dt^2} - 4 \frac{dy}{dt} + 4y = 0$
(A)	$y = A \sin(2t) + B$
(B)	$y = A \sin(2t) + B \cos(2t)$
(C)	$y = A e^{2t} + B e^{-2t}$
(D)	$y = A e^{2t} + B t e^{2t}$

Q.37	Which one of the following equations will fail to converge to a root with an initial guess value of $x = 0.5$, using the Newton-Raphson method?
(A)	$x(1-x) = 0$
(B)	$e^x - 3x^2 = 0$
(C)	$x - \ln(3x) = 0$
(D)	$\tan(x) - x = 0$



GATE 2022 Metallurgical Engineering (MT)

Q.38	Match the following mineral processing operations (Column I) with the corresponding physical principles (Column II)	
	Column I	Column II
	(P) Flotation	(1) Difference in speed of lateral movements
	(Q) Jigging	(2) Hydrophobicity
	(R) Tabling	(3) Difference in size reduction
	(S) Comminution	(4) Difference in initial acceleration
(A)	P – 2, Q – 4, R – 1, S – 3	
(B)	P – 2, Q – 3, R – 1, S – 4	
(C)	P – 3, Q – 1, R – 4, S – 2	
(D)	P – 1, Q – 4, R – 2, S – 3	

GATE 2022 Metallurgical Engineering (MT)

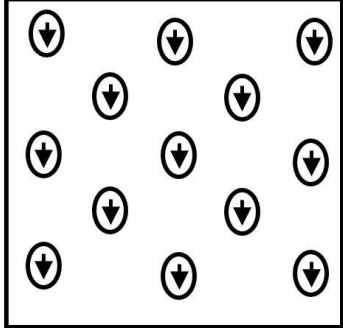
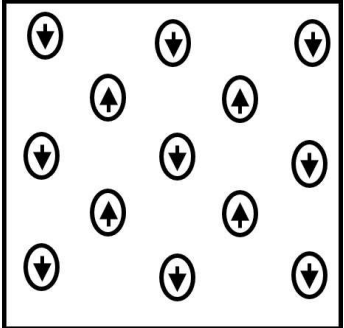
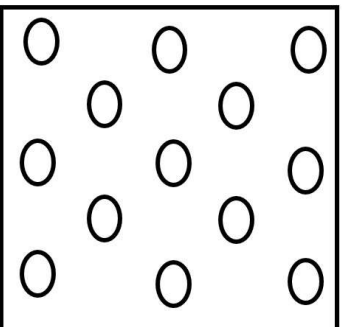
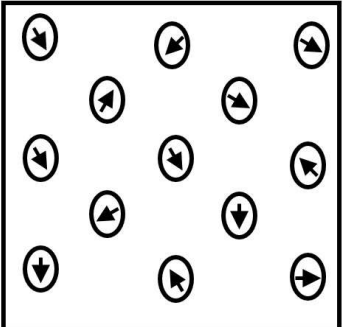
<p>Q.39</p>	<p>Figures P, Q, R and S schematically show the atomic dipole moments in the absence of external magnetic field. Which one of the following is the correct mapping of nature of magnetism to atomic dipole moments?</p>
	<div style="display: flex; justify-content: space-around; align-items: center;"> <div style="text-align: center;">  <p>P</p> </div> <div style="text-align: center;">  <p>Q</p> </div> </div> <div style="display: flex; justify-content: space-around; align-items: center; margin-top: 20px;"> <div style="text-align: center;">  <p>R</p> </div> <div style="text-align: center;">  <p>S</p> </div> </div>
<p>(A)</p>	<p>P – Diamagnetism, Q – Antiferromagnetism, R – Paramagnetism, S – Ferromagnetism</p>
<p>(B)</p>	<p>P – Ferromagnetism, Q – Antiferromagnetism, R – Diamagnetism, S – Paramagnetism</p>
<p>(C)</p>	<p>P – Paramagnetism, Q – Ferromagnetism, R – Diamagnetism, S – Antiferromagnetism</p>
<p>(D)</p>	<p>P – Ferromagnetism, Q – Diamagnetism, R – Antiferromagnetism, S – Paramagnetism</p>



GATE 2022 Metallurgical Engineering (MT)

Q.40	Find the correct match between dislocation reactions (Column A) to the descriptions (Column B)								
	<table border="0" style="width: 100%;"> <thead> <tr> <th style="text-align: left; width: 50%;">Column A</th> <th style="text-align: left; width: 50%;">Column B</th> </tr> </thead> <tbody> <tr> <td>(P) $\frac{a_0}{2} [\bar{1} \bar{1} 1] + \frac{a_0}{2} [111] = a_0 [001]$</td> <td>(1) Leading partials merging to form a Lomer-Cottrell lock in an FCC metal</td> </tr> <tr> <td>(Q) $\frac{a_0}{6} [\bar{1}2\bar{1}] + \frac{a_0}{6} [1\bar{1}2] = \frac{a_0}{6} [011]$</td> <td>(2) Energetically unfavorable dislocation reaction in an FCC metal</td> </tr> <tr> <td>(R) $\frac{a_0}{6} [1\bar{2}1] + \frac{a_0}{6} [\bar{1} \bar{1} 2] = \frac{a_0}{2} [0\bar{1}1]$</td> <td>(3) Typical dislocation reaction in a BCC metal</td> </tr> </tbody> </table>	Column A	Column B	(P) $\frac{a_0}{2} [\bar{1} \bar{1} 1] + \frac{a_0}{2} [111] = a_0 [001]$	(1) Leading partials merging to form a Lomer-Cottrell lock in an FCC metal	(Q) $\frac{a_0}{6} [\bar{1}2\bar{1}] + \frac{a_0}{6} [1\bar{1}2] = \frac{a_0}{6} [011]$	(2) Energetically unfavorable dislocation reaction in an FCC metal	(R) $\frac{a_0}{6} [1\bar{2}1] + \frac{a_0}{6} [\bar{1} \bar{1} 2] = \frac{a_0}{2} [0\bar{1}1]$	(3) Typical dislocation reaction in a BCC metal
Column A	Column B								
(P) $\frac{a_0}{2} [\bar{1} \bar{1} 1] + \frac{a_0}{2} [111] = a_0 [001]$	(1) Leading partials merging to form a Lomer-Cottrell lock in an FCC metal								
(Q) $\frac{a_0}{6} [\bar{1}2\bar{1}] + \frac{a_0}{6} [1\bar{1}2] = \frac{a_0}{6} [011]$	(2) Energetically unfavorable dislocation reaction in an FCC metal								
(R) $\frac{a_0}{6} [1\bar{2}1] + \frac{a_0}{6} [\bar{1} \bar{1} 2] = \frac{a_0}{2} [0\bar{1}1]$	(3) Typical dislocation reaction in a BCC metal								
(A)	P – 3, Q – 2, R – 1								
(B)	P – 3, Q – 1, R – 2								
(C)	P – 2, Q – 3, R – 1								
(D)	P – 2, Q – 1, R – 3								



GATE 2022 Metallurgical Engineering (MT)

Q.41	Match the phenomena (Column I) with the descriptions (Column II)	
	Column I	Column II
	(P) Cottrell atmosphere	(1) Decrease in yield stress when loading direction is reversed
	(Q) Suzuki interaction	(2) Stress assisted diffusion of vacancies resulting in plastic deformation in a polycrystalline material
	(R) Bauschinger effect	(3) Lüders bands
	(S) Nabarro-Herring creep	(4) Segregation of solutes to the stacking fault
(A)	P – 1, Q – 2, R – 3, S – 4	
(B)	P – 1, Q – 2, R – 4, S – 3	
(C)	P – 3, Q – 4, R – 1, S – 2	
(D)	P – 3, Q – 1, R – 4, S – 2	

**GATE 2022 Metallurgical Engineering (MT)**

Q.42	For a 3×3 matrix, the value of the determinant is -48 and the trace is 8 . If one of the eigenvalues is 4 , the other two are _____
(A)	$2, -3$
(B)	$1, -3$
(C)	$6, -2$
(D)	$-4, 0$



GATE 2022 Metallurgical Engineering (MT)

Q.43 – Q.45 Multiple Selection Question (MSQ), carry TWO marks each

Q.43	Which of the following statement(s) is(are) TRUE about black body radiation?
(A)	Among all radiation emitted by an ideal black body at room temperature, the most intense radiation falls in the visible light spectrum
(B)	The total emissive power of an ideal black body is proportional to the square of its absolute temperature
(C)	The emissive power of an ideal black body peaks at a wavelength λ which is inversely proportional to its absolute temperature
(D)	The radiant energy emitted by an ideal black body is greater than that emitted by the non-black body at all temperatures above 0 K

Q.44	Which of the following parameter(s) influence(s) the melting rate of the consumable wire in a gas metal arc welding process?
(A)	Stick-out length
(B)	Welding speed
(C)	Welding current
(D)	Diameter of the consumable wire

GATE 2022 Metallurgical Engineering (MT)

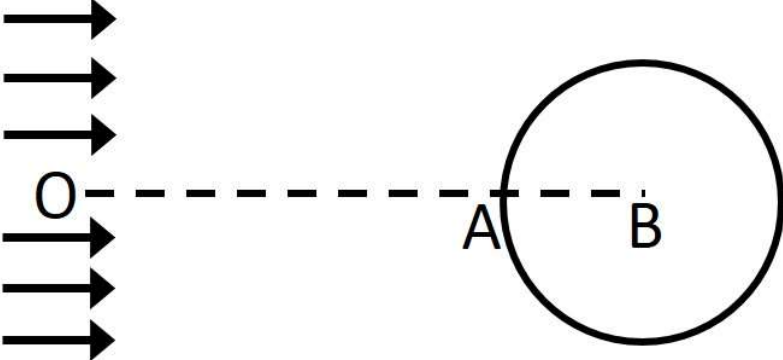
<p>Q.45</p>	<p>A non-rotating smooth solid spherical object is fixed in the stream of an inviscid incompressible fluid of density ρ (see figure). The flow is horizontal, slow, steady, and fully developed far from the object as shown by the streamline arrows near point O. Which of the following statement(s) is(are) TRUE?</p> <p>(Note: B is the center of the sphere and the straight horizontal line OAB intersects the surface of the sphere at the point A.)</p>
	
<p>(A)</p>	<p>The velocity of the fluid at the point A is zero</p>
<p>(B)</p>	<p>The fluid pressure at the point A exceeds that at point O by the amount $\frac{\rho v^2}{2}$, where v is the fluid velocity at point O</p>
<p>(C)</p>	<p>Fluid moving precisely along OA will turn perpendicular to OA to circumvent the object</p>
<p>(D)</p>	<p>On each side of the central streamline OA, the flow will be deflected round the object</p>



GATE 2022 Metallurgical Engineering (MT)

Q.46 – Q.65 Numerical Answer Type (NAT), carry TWO marks each

Q.46	From high temperature tensile testing, the flow stress (measured at the same value of strain) of an alloy was found to be 50 MPa at a strain rate of 0.1 s^{-1} and 70 MPa at a strain rate of 10 s^{-1} . The strain rate sensitivity parameter is _____ (round off to 3 decimal places).
------	--

Q.47	A spherical gas bubble of radius 0.01 mm is entrapped in molten steel held at 1773 K. If the pressure outside the bubble is 1.5 bar, the pressure inside the bubble is _____ bar (round off to 1 decimal place). Given: 1 bar = 10^5 Pa and the surface tension of the steel at 1773 K is $1.4 \text{ N} \cdot \text{m}^{-1}$.
------	--

Q.48	What is the equilibrium $\frac{p_{\text{CO}}}{p_{\text{CO}_2}}$ ratio for the given reaction at 1873 K? (round off to 2 decimal places) $\text{Mo(s)} + \text{O}_2(\text{g}) \leftrightarrow \text{MoO}_2(\text{s})$ Given: $\Delta_f G_{1873}^\circ = -262300 \text{ J}$; $a_{\text{MoO}_2(\text{s})} = 0.5$ and $\Delta_r G_{1873}^\circ = -120860 \text{ J}$ for the reaction $\text{CO}(\text{g}) + 0.5\text{O}_2(\text{g}) \leftrightarrow \text{CO}_2(\text{g})$; $R = 8.314 \text{ J} \cdot \text{K}^{-1} \cdot \text{mol}^{-1}$.
------	---

Q.49	The emf of the cell $\text{Au-Pb(liquid)} \mid \text{PbCl}_2\text{-KCl(liquid)} \mid \text{Cl}_2(\text{gas}, 0.5 \text{ atm}), \text{C(graphite)}$ is 1.2327 V at 873 K. Activity of Pb in the Au-Pb alloy is 0.72 and the activity of PbCl_2 in the electrolyte is 0.18. The standard Gibbs energy of formation of $\text{PbCl}_2(\text{liquid})$ at 873 K is _____ $\text{kJ} \cdot \text{mol}^{-1}$ (round off to 1 decimal place). Given: $R = 8.314 \text{ J} \cdot \text{K}^{-1} \cdot \text{mol}^{-1}$ and $F = 96500 \text{ C} \cdot \text{mol}^{-1}$.
------	---



GATE 2022 Metallurgical Engineering (MT)

Q.50	Consider a tilt boundary of misorientation of 2° in an aluminium grain. The lattice parameter of aluminium is 0.143 nm. The spacing between the dislocations that form the tilt boundary is _____ nm (round off to 2 decimal places).
------	--

Q.51	Molten steel at 1873 K weighing 100 metric tons is desulfurized using 1250 kg of synthetic slag by equilibration. If the sulfur content in the steel is reduced from 0.015 mass% to 0.0025 mass%, the desulfurizing index is _____ (round off to the nearest integer).
------	--

Q.52	<p>High cycle fatigue data for an alloy at various alternating stresses, σ_a (see figure) is given below</p> <table border="1" style="margin-left: auto; margin-right: auto;"> <thead> <tr> <th style="text-align: center;">Stress, σ_a (MPa)</th> <th style="text-align: center;">N_f, Number of cycles to failure</th> </tr> </thead> <tbody> <tr> <td style="text-align: center;">500</td> <td style="text-align: center;">1000</td> </tr> <tr> <td style="text-align: center;">400</td> <td style="text-align: center;">10000</td> </tr> <tr> <td style="text-align: center;">300</td> <td style="text-align: center;">100000</td> </tr> <tr> <td style="text-align: center;">200</td> <td style="text-align: center;">1000000</td> </tr> </tbody> </table> <div style="text-align: right; margin-top: 10px;"> </div> <p>A specimen of this alloy is subjected to multiple stress cycles sequentially in the following order: (i) first 5000 cycles at $\sigma_a = 400$ MPa followed by (ii) 25000 cycles at $\sigma_a = 300$ MPa and finally (iii) at $\sigma_a = 500$ MPa. Assuming that Miner's law is obeyed, the number of cycles to failure at the final applied stress of 500 MPa is _____.</p>	Stress, σ_a (MPa)	N_f , Number of cycles to failure	500	1000	400	10000	300	100000	200	1000000
Stress, σ_a (MPa)	N_f , Number of cycles to failure										
500	1000										
400	10000										
300	100000										
200	1000000										



GATE 2022 Metallurgical Engineering (MT)

Q.53 The partial molar enthalpy of Au in Ag-Au melt containing 25 mol% Au at 1400 K is $-8300 \text{ J}\cdot\text{mol}^{-1}$. Assuming regular solution behavior, the activity of Au in the melt is _____ (round off to 3 decimal places).

Given: $R = 8.314 \text{ J}\cdot\text{K}^{-1}\cdot\text{mol}^{-1}$

Q.54 A rectangular block made of Material I and Material II of identical cross sections (as shown in the figure) has a temperature (T) of 435 K and 400 K at the bottom and top surfaces, respectively. Assuming purely steady state conductive heat transfer, the temperature at the interface is _____ K (round off to nearest integer).

(Given: The two parts of the block made of Material I and Material II have equal thickness of 25 mm each. The thermal conductivities of Material I and Material II are $50 \text{ W}\cdot\text{m}^{-1}\cdot\text{K}^{-1}$ and $200 \text{ W}\cdot\text{m}^{-1}\cdot\text{K}^{-1}$, respectively.)

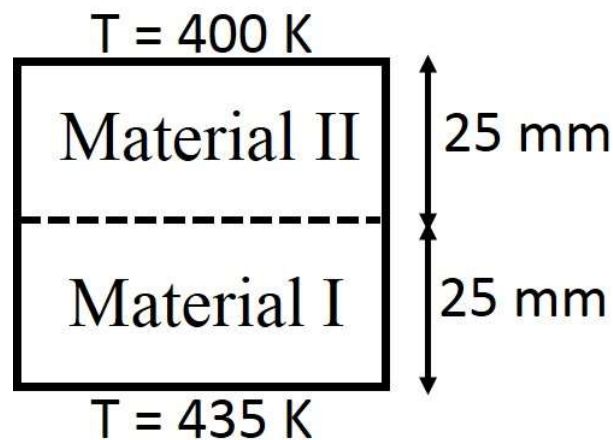



GATE 2022 Metallurgical Engineering (MT)

Q.55	<p>During solidification of a pure metal, the radius of critical nucleus at an undercooling of 10 K is _____ $\times 10^{-9}$ m (answer rounded off to 1 decimal place).</p> <p>Given: solid/liquid interface energy = $0.177 \text{ J}\cdot\text{m}^{-2}$,</p> <p>melting point of the metal = 1356 K and</p> <p>latent heat of fusion = $1.88 \times 10^9 \text{ J}\cdot\text{m}^{-3}$</p>
------	---

Q.56	<p>The concentration C of a solute (in units of $\text{atoms}\cdot\text{mm}^{-3}$) in a solid along x direction (for $x > 0$) follows the expression</p> $C = a_1x^2 + a_2x$ <p>where x is in mm, a_1 and a_2 are in units of $\text{atoms}\cdot\text{mm}^{-5}$ and $\text{atoms}\cdot\text{mm}^{-4}$, respectively. Assuming $a_1 = a_2 = 1$, the magnitude of flux at $x = 2$ mm is _____ $\times 10^{-3} \text{ atoms}\cdot\text{mm}^{-2}\cdot\text{s}^{-1}$ (answer rounded off to the nearest integer).</p> <p>Given: diffusion coefficient of the solute in the solid is $3 \times 10^{-3} \text{ mm}^2\cdot\text{s}^{-1}$.</p>
------	---



GATE 2022 Metallurgical Engineering (MT)

Q.57	<p>Assuming that Dulong-Petit law is valid for a monoatomic solid, the ratio of heat capacities $\frac{C_p}{C_v}$ at 500 K is _____ (round off to 3 decimals).</p> <p>Given: molar volume = $7 \times 10^{-6} \text{ m}^3 \cdot \text{mol}^{-1}$, isothermal compressibility = $8 \times 10^{-12} \text{ Pa}^{-1}$, isobaric expansivity = $6 \times 10^{-5} \text{ K}^{-1}$ and $R = 8.314 \text{ J} \cdot \text{K}^{-1} \cdot \text{mol}^{-1}$.</p>
Q.58	<p>A sieve made of steel wire of diameter $53 \mu\text{m}$ has an aperture size of $74 \mu\text{m}$. Its mesh number is _____ (round off to the nearest integer).</p>
Q.59	<p>Steel plates are welded autogenously using Gas Tungsten Arc welding with an arc heat transfer efficiency of 0.65. The first weld is made using a welding current of 200 A at an arc voltage of 18 V with a welding speed of $0.002 \text{ m} \cdot \text{s}^{-1}$. The second weld is made at a welding speed of $0.0022 \text{ m} \cdot \text{s}^{-1}$ with the same arc voltage. If both the welds have identical heat input, the welding current of the second weld is _____ A (round off to the nearest integer).</p>
Q.60	<p>A cylindrical specimen of an Al alloy with diameter of 30 mm is cold extruded to a diameter of 20 mm. If the flow behavior of the alloy is expressed by the equation, $\sigma = 350 \epsilon^{0.3} \text{ MPa}$, the ideal plastic work of deformation per unit volume is _____ $\times 10^6 \text{ J}$ (answer rounded off to the nearest integer).</p>



GATE 2022 Metallurgical Engineering (MT)

Q.61	The integral of the function $f(x) = 0.2 + 10x^2$ estimated by the trapezoidal rule with a single segment from $x = 0$ to $x = 1$ is _____ (round off to 1 decimal place).
Q.62	Air at 300 K is passed at a mass flow rate of $1.5 \text{ kg}\cdot\text{s}^{-1}$ through a metallic tube of inner diameter 0.08 m. Inner wall temperature of the tube is maintained at 700 K. Temperature of the air leaving the tube is 600 K. Assuming that heat transfer occurs entirely by steady state convection, length of the tube is _____ m (round off to 2 decimal places). Given: the coefficient of convective heat transfer from tube wall to air is $500 \text{ W}\cdot\text{m}^{-2}\cdot\text{K}^{-1}$. Assume specific heat capacity of air to be constant and equal to $1080 \text{ J}\cdot\text{kg}^{-1}\cdot\text{K}^{-1}$ and $\pi = 3.14$
Q.63	Given the stress tensor $\begin{bmatrix} 130 & 30 & 0 \\ 30 & 50 & 0 \\ 0 & 0 & 0 \end{bmatrix} \text{ MPa,}$ the maximum shear stress is _____ MPa (round off to the nearest integer).
Q.64	A set of 11 (x, y) data points is least-squares fitted to a quadratic polynomial. If the sum of squares of error is 2.4, the variance of error is _____ (round off to 1 decimal place).
Q.65	The equilibrium microstructure of an alloy A-B consists of two phases α and β in the molar proportion 2:1. If the overall composition of the alloy is 70 mol% B and the composition of β is 90 mol% B, the composition of α is _____ (in mol% B) (round off to the nearest integer).